

Lithium Manganese Dioxide Coin Battery : Individual Specification

CR1216

Nominal Voltage	3V	Dimensions (mm) 	A	∅10.4
Nominal Capacity	25(mAh)		B	∅12.5 ^{+0.0} _{-0.2}
Continuous standard load	62(KΩ)		C	1.3
Operating temperature	-20~60°C		D	1.6 ^{+0.0} _{-0.2}
Weight	0.7(g)			

Discharge characteristics

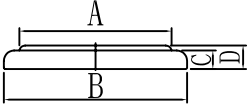
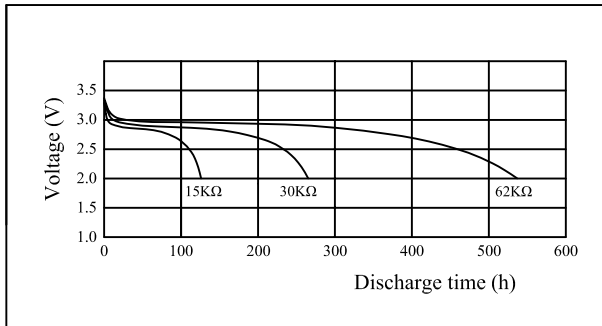

Temperature characteristics

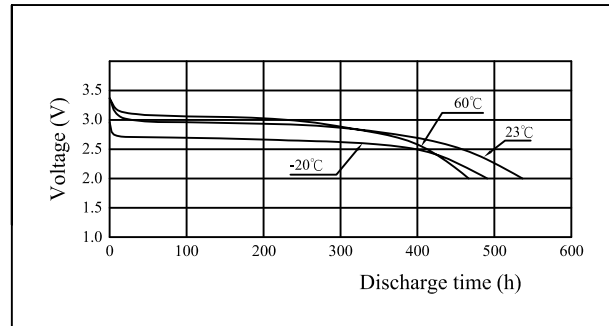

Load vs. Operating voltage

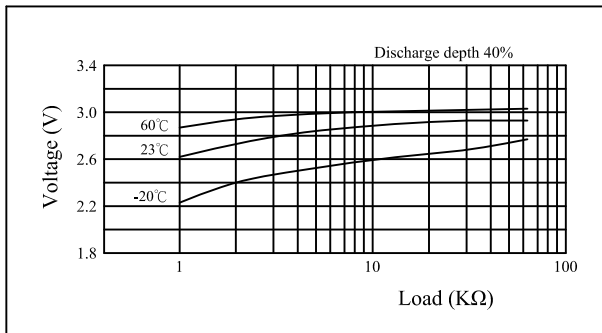

Load vs. Capacity

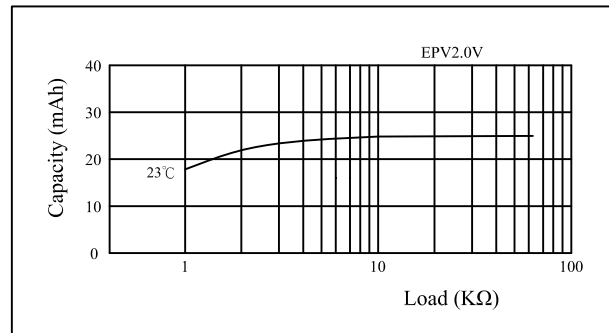

Pulse discharge characteristics

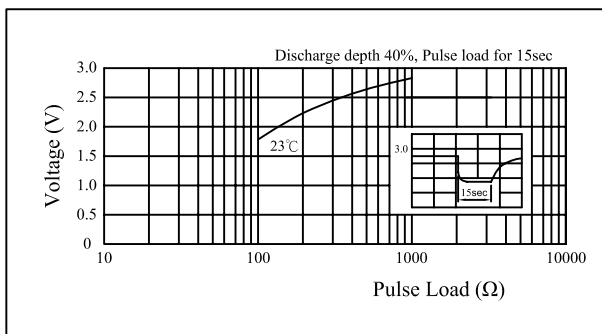

Storage characteristics

